



qlayers

**WENN ES EXISTIERT, WURDE ES BESCHICHTET**



UNSICHER



INEFFIZIENT



MANUELLES  
BESCHICHTEN



Height

54 ft (16 m)

Tank Type

Fixed cone roof

Diameter

142 ft (43 m)



# Qlayers überliegt konventionellen Methoden in jeglicher Hinsicht

	qlayers	Manuelles Rollen	Manuelles Sprühen	Alternative Sprühroboter
Praktisch kein Overspray				
Wind				
Niedriger Farbverlust				
Geschwindigkeit				
Sicherheit				
Konsistente Qualität				

# Patentiertes Abschirmsystem ermöglicht Sprühen mit praktisch keinem Overspray (<1%)

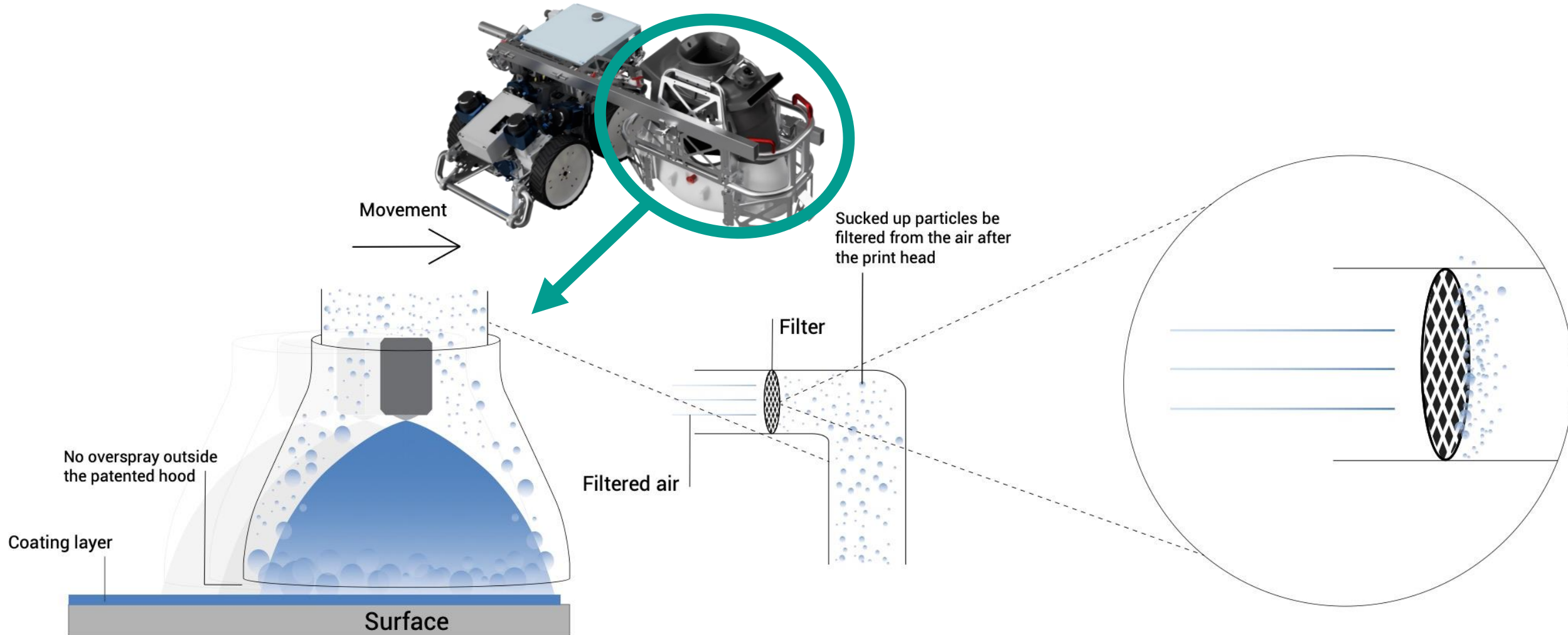

# Roboter zum Beschichten von Lagertanks, Windturbinen und Schiffen



## Neue Era der industriellen Beschichtung



Beschichtung von **200 m<sup>2</sup>/h**

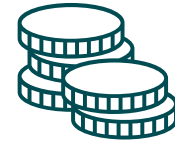

**Spart** bis zu 20 % **Farbe**



**Minimale** Arbeit in gefährlicher Höhe

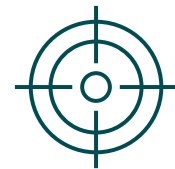

**Konsistente Schichtstärke** auf der gesamten Fläche



Schutzschild ermöglicht Sprühen **sogar bei Wind** (max 4 Bft.)



**Praktisch kein "Overspray"** (<1%) verhindert Ausstoß schädlicher Chemikalien



# Reduktion von Overspray für eine sichere und effiziente Anwendung

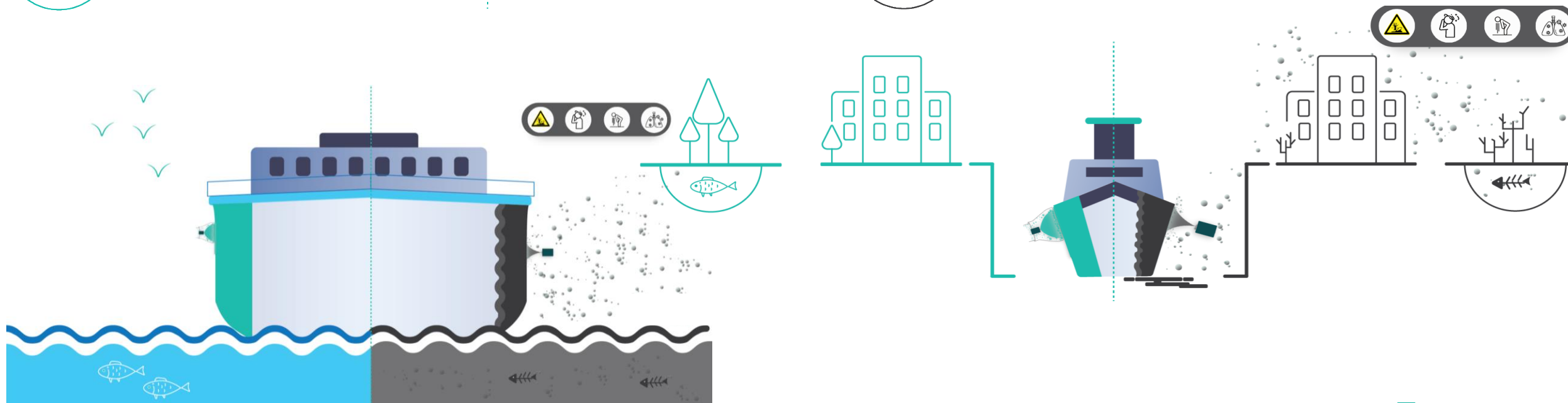
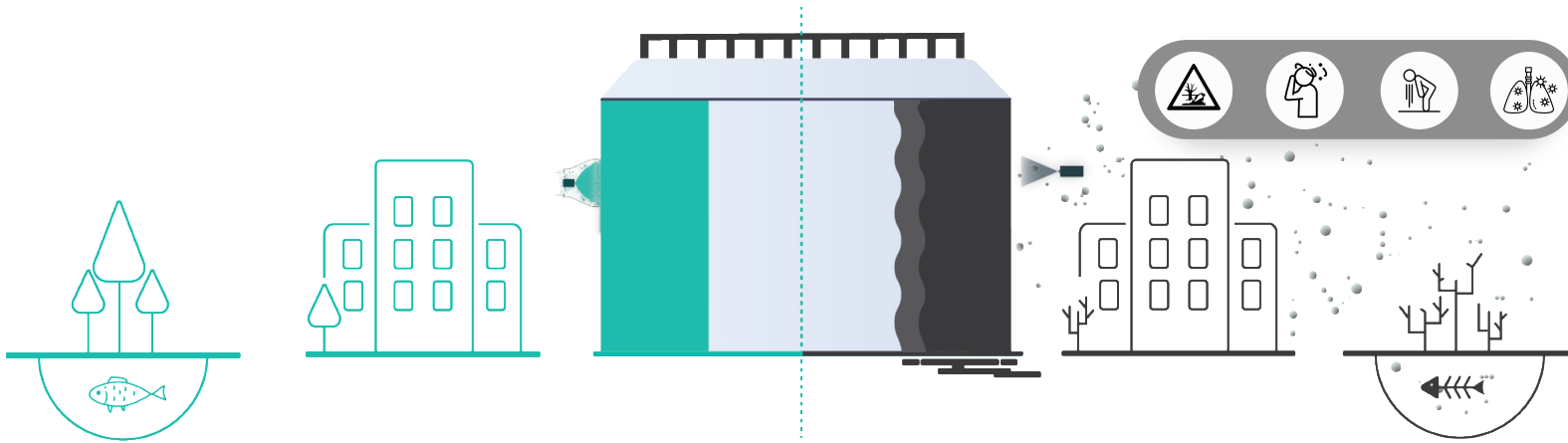

# Steuerung des Roboters aus sicherer Position

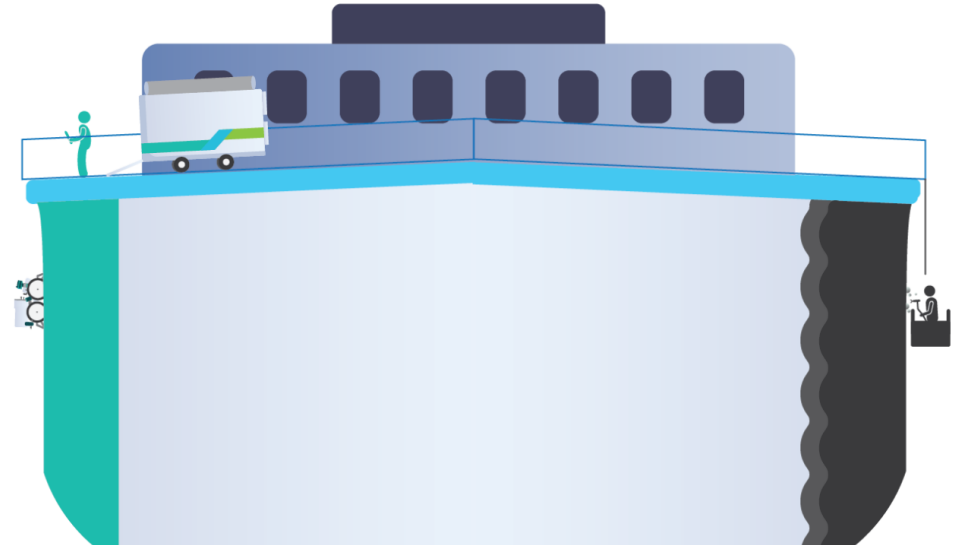
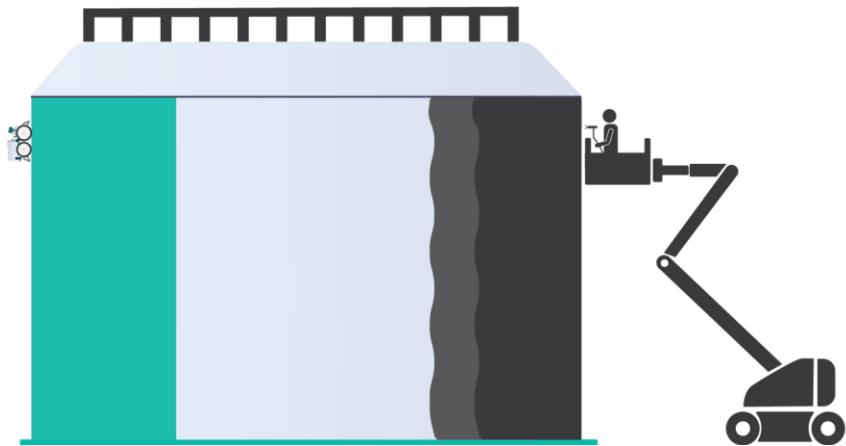

# Deutliche Überlegenheit gegenüber der manuellen Qualität

Manuelle  
Beschichtung



Automatisierte  
Anwendung

# Täglicher Bericht und Live-Dashboard ermöglichen den Überblick

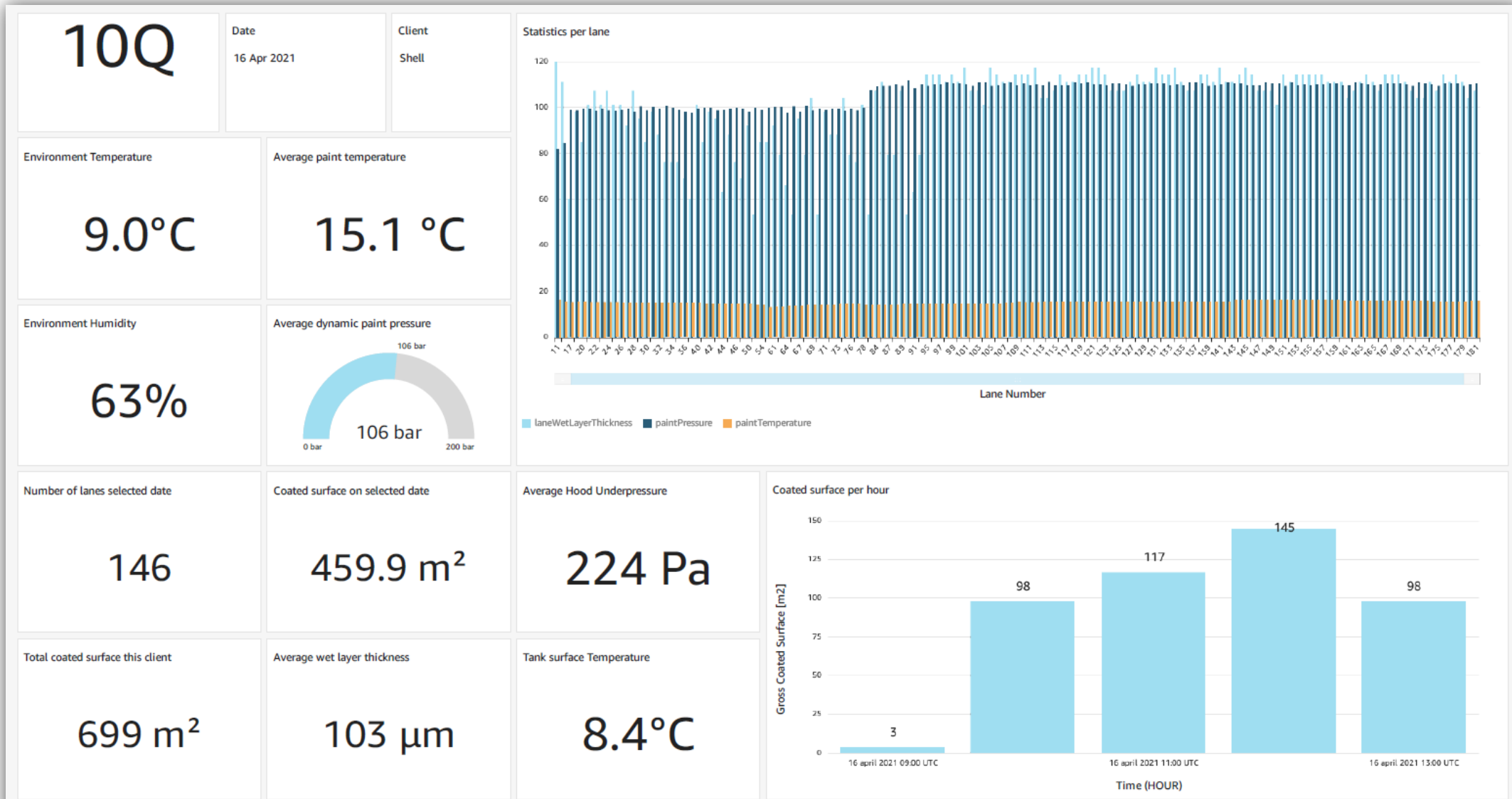

## TK154: Shell Bukom (Singapur)



### PROJEKTRAHMEN

Terminal: Shell Bukom

Standort: Singapur

Tanknummer: TK154

Höhe: 21,9 m

Durchmesser: 76,2 m

Korrosionsschutzdienstleister: Altrad Services Singapore Pte Ltd

Beschichtete Fläche: 4.688 m<sup>2</sup>

Ausgewählte Lacke:

Interzone 954 (primer), Interthane® 990 (topcoat)



# Hohe Qualität gepaart mit Effizienz in der Applikation

350  $\mu\text{m}$

Ø Nassschichtstärke  
Grundierung

150  $\mu\text{m}$

Ø Nassschichtstärke  
Topcoat

180  $\text{m}^2/\text{h}$

Höchstgeschwindigkeit

Hohe Qualität gemäß Produktdatenblatt  
– **alle Standards erfüllt**

Erfolgreiche Abnahme  
durch Inspektion



## TK A331: Shell Deer Park (USA)

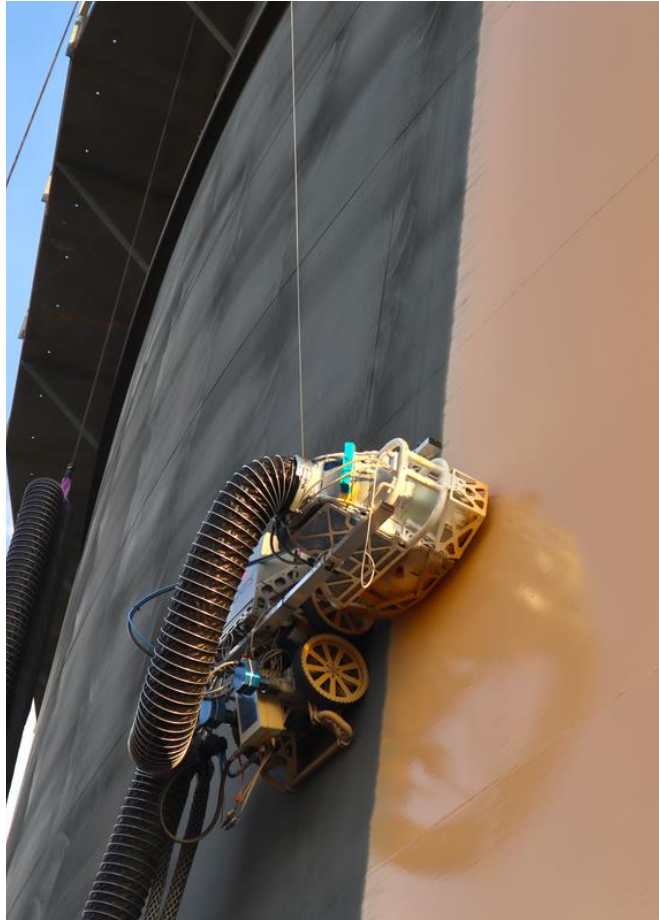

### PROJEKTRAHMEN

Terminal: Shell Deer Park

Standort: Texas, USA

Tanknummer: TK A331

Höhe: 17 m

Durchmesser: 60 m

Korrosionsschutzdienstleister: Partner Industrial

Beschichtete Fläche: 3747 m<sup>2</sup>

Ausgewählte Lacke:

Interseal® 670HS (primer), Interthane® 990 (topcoat)



qlayers



qlayers

Applying coatings of the future

100 - COATING TANKS  
AUTOMATICALLY



## Testimonials zeigen erfreuliche Ergebnisse

*“The work on the tank exceeded expectations for productivity, with a large area been completed in a very short time span. Importantly for us, work was able to proceed in wind conditions that would have stopped either roller or airless application so widening the window for application is a benefit.”*

-Shell

*“We were extremely happy with the robot, it was intuitive and straightforward to use and we estimate that we would have had another 2-3 weeks work with roller application if the robot was not used. This offers a significant opportunity to improve productivity so we are looking forward to working together of further jobs.”*

-Partner Industrial



# Bereits erfolgreiche Projekte mit Shell in Singapur, USA, Niederlande. Positive Testimonials der Anlagenbesitzer



**Shell Global Solutions International B.V.**

Energy Transition Campus Amsterdam  
Grasweg 31  
1013 HW AMSTERDAM  
The Netherlands

**Direct Tel** +31206307259

**Email** [carolin.vermeiden@shell.com](mailto:carolin.vermeiden@shell.com)

**Internet** [www.shell.com](http://www.shell.com)

Josefien Groot  
CEO Qlayers B.V.

February 2023

Subject: non-binding testimonial robotic tank coating at Shell

L.S.,

This is to express our continued interest in the 10Q robotic tank coating technology for above-ground storage tanks as developed by Qlayers B.V. in The Netherlands. We have been providing the Qlayers team feedback on this development from an Asset Owner's perspective and trialed various versions in locations spread around the world (Europe, Americas, Asia).

Key benefits of this technology are in the safety, environmental and productivity domains.

- it enables the reduction of safety exposure hours (less man hours spent working at heights)
- it minimises emissions to the environment (also known as "overspray")
- it increases application speed – given adequate preparation and execution conditions, it enables tank coating scopes to be executed in much less time than conventional methods

In our test deployments, we have seen that local availability of the technology is necessary to ensure affordability and adequate response times, to develop and sustain adequate local competence for operating the robots, and to familiarise potential customers with the technology.

We are currently working with our colleagues on Shell sites around the world, to help them identify opportunities for value-adding use of this technology and continue to support them to deliver these opportunities successfully.

*Disclaimer: this testimonial does not constitute a formal commitment to any party. Shell is not liable to any party for their use of this technology.*

Yours sincerely,  
Shell Global Solutions International B.V.

Caroline Vermeiden  
Contracting & Procurement – Technology Deployment & Replication Program Lead

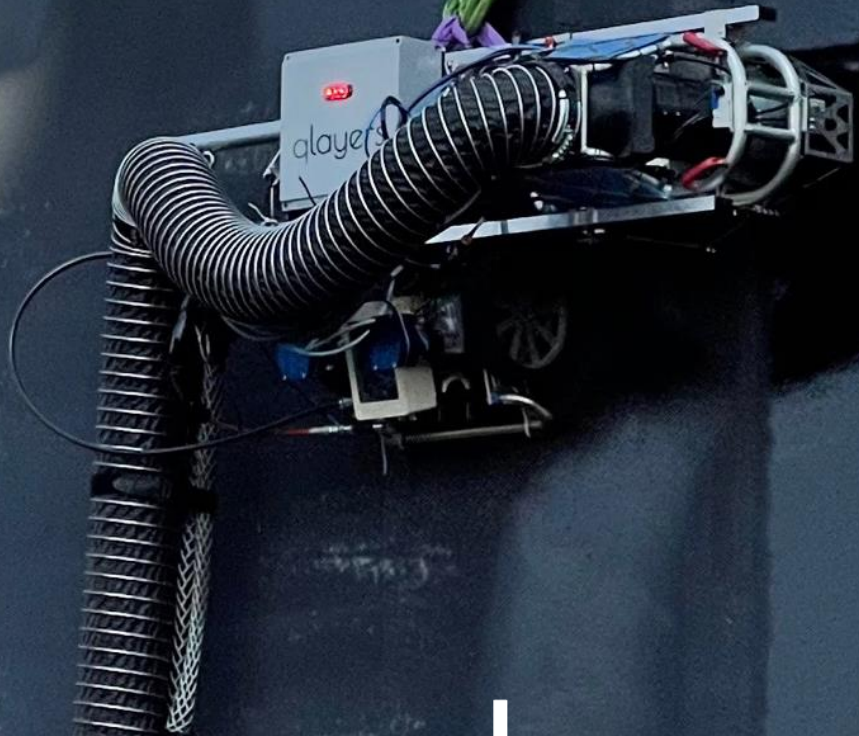

 KONTAKT

# qlayers

Let's apply the  
coatings of the future

**Christopher Schneider**  
Revenue Operations Manager

+43 676 84 66 66 905  
christopher@qlayers.com